

Proportional 2-way flow control cartridge

- ◆ direct operated
- ◆ $Q_{max} = 25 \text{ l/min}$
- ◆ $Q_{Nmax} = 25 \text{ l/min}$
- ◆ $p_{max} = 350 \text{ bar}$

M22 x 1,5
ISO 7789

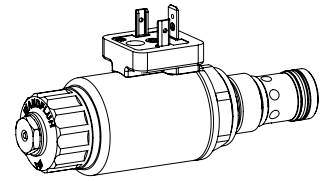

DESCRIPTION

Direct operated, pressure compensated proportional flow control valve in screw-in cartridge construction for cavity according to ISO 7789. With the solenoid deenergised, the control spool is held in the closed position (QN) or open position (QO) by a spring. The change of the electric current is followed by a proportional volume flow change. From the input (1), the fluid flows over a throttle and a control spool to the controlled output (2). For the control, Wandfluh proportional amplifiers are available (see register 1.13).

APPLICATION

Proportional flow control valves are suitable for precise speed control, where the load current has to be maintained constant independent of the input and output pressure. The screw-in cartridge is perfectly suitable for installation in control blocks and is installed in sandwich- (vertical stacked systems) and in flange plates (corresponding data sheets in this register). For machining the cartridge cavity in steel and aluminum blocks, cavity tools are available (hire or purchase). Please refer to the data sheets in register 2.13.

SYMBOL

Simplified

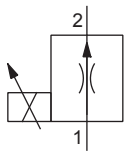

Detailed QN...

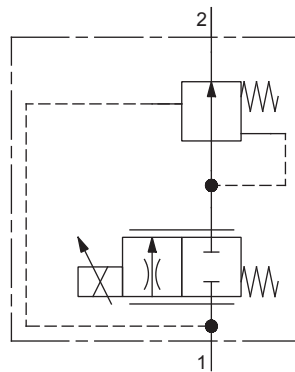

Detailed QO...

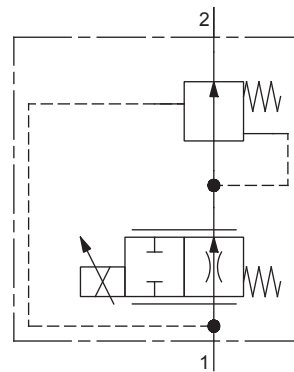

GENERAL SPECIFICATIONS

Designation	Proportional 2-way flow control valve
Construction	Direct operated
Mounting	Screw-in cartridge construction
Nominal size	M22 x 1,5 according to ISO 7789
Actuation	Proportional solenoid
Ambient temperature	-25...+70 °C
Weight	0,64 kg
MTTFd	150 years

ELECTRICAL SPECIFICATIONS

Protection class	Connection execution D: IP65 Connection execution J: IP66 Connection execution G: IP67 and IP69K
Relative duty factor	100 % DF
Standard nominal voltage	12 VDC, 24 VDC
Limiting current at 50 °C	$I_G = 1360 \text{ mA}$ ($U_N = 12\text{VDC}$) $I_G = 680 \text{ mA}$ ($U_N = 24\text{VDC}$)

Note!



Other electrical specifications see data sheet 1.1-173 (slip-on coil W) and 1.1-174 (slip-on coil M)

TYPE CODE

Flow control valve		Q	P	PM22	-		-		/			-			#	
Normally closed																
Normally open																
Proportional																
Screw-in cartridge	M22 x 1,5															
Nominal volume flow rate Q_N	normally closed															
	3,2 l/min															
	8 l/min															
	16 l/min															
	25 l/min															
Nominal voltage U_N	12 VDC															
	24 VDC															
	without coil															
Slip-on coil	Metal housing round															
	Metal housing square															
Connection execution	Connector socket EN 175301-803 / ISO 4400															
	Connector socket AMP Junior-Timer															
	Connector Deutsch DT04-2P															
Sealing material	NBR															
	FKM (Viton)															
Manual override																

Design index (subject to change)

2.6-631

ACTUATION

Actuation	Proportional solenoid, wet pin push type, pressure tight
Execution	W.S37 / 19 x 50 (Data sheet 1.1-173) M.S35 / 19 x 50 (Data sheet 1.1-174)
Connection	Connector socket EN 175301 – 803 Connector socket AMP Junior-Timer Connector Deutsch DT04 – 2P

HYDRAULIC SPECIFICATIONS

Working pressure	$p_{max} = 350$ bar
Maximum volume flow	$Q_{max} = 25$ l/min
Minimum volume flow	$Q_{min} = 0,1$ l/min
Volume flow direction	1 → 2
Leakage oil	See characteristics
Nominal volume flow range	$Q_N = 3,2; 8; 16; 25$ l/min (QN) $Q_N = 3,2$ l/min (QO)
Hysteresis	≤ 6 % (QN); 10 % (QO) at optimal dither signal
Repeatability	≤ 2 % at optimal dither signal
Fluid	Mineral oil, other fluid on request
Viscosity range	12 mm ² /s...320 mm ² /s
Temperature range fluid	-25...+70 °C (NBR) -20...+70 °C (FKM)
Contamination efficiency	Class 18 / 16 / 13
Filtration	Required filtration grade β 6...10 ≥ 75, see data sheet 1.0-50

PERFORMANCE SPECIFICATIONS

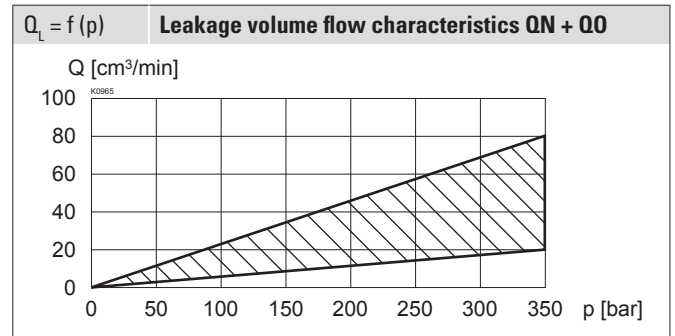
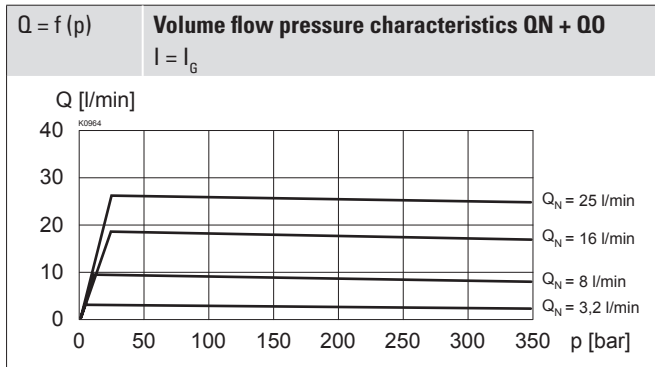
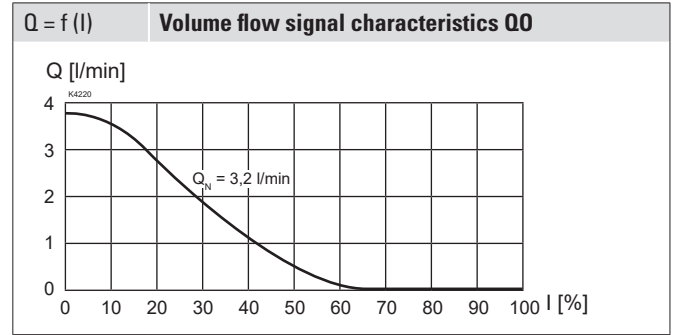
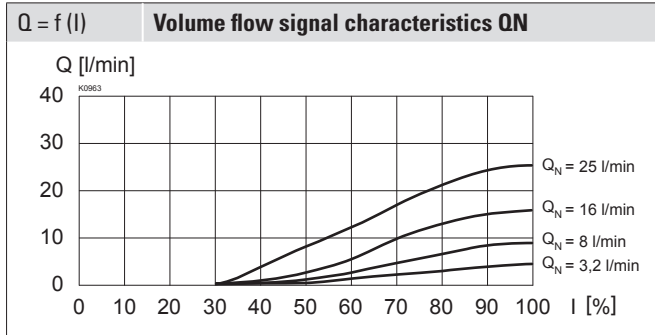
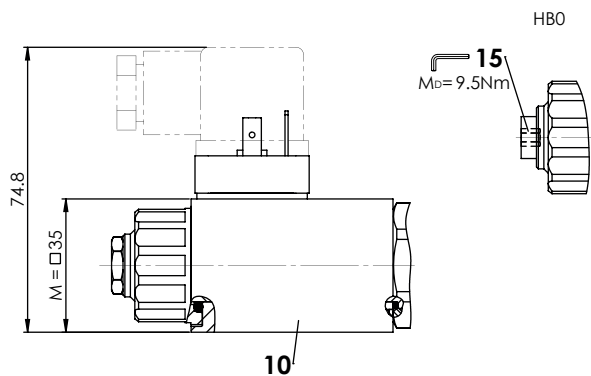
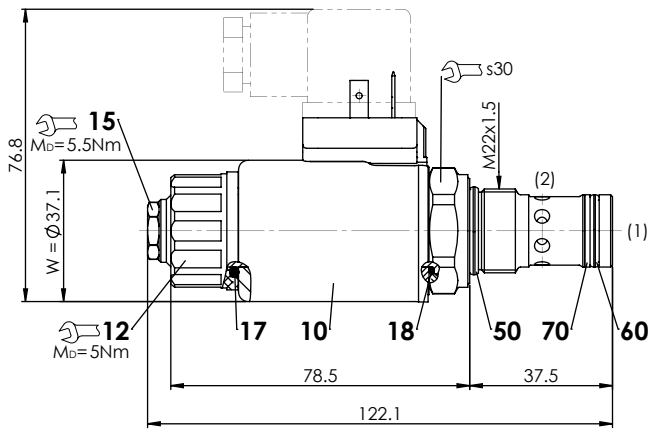
 Oil viscosity $\nu = 30 \text{ mm}^2/\text{s}$

DIMENSIONS

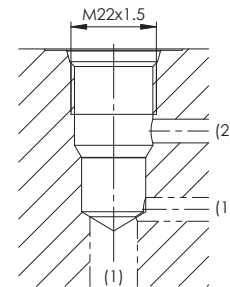
HYDRAULIC CONNECTION

Cavity drawing according to ISO 7789-22-01-0-98

Note!

For detailed cavity drawing and cavity tools see data sheet 2.13-1008

PARTS LIST

Position	Article	Description
10	206.2...	W.S37 / 19 x 50
	260.5...	M.S35 / 19 x 50
12	154.2700	Knurled nut
15	253.8000	HB4,5 manual override
	239.2033	HBO Screw plug
-	251.3222	Seal kit

Seal kit consisting of

17	O-ring	ID 18,72 x 2,62
18	O-ring	ID 17,17 x 1,78
50	O-ring	ID 18,77 x 1,78
60	O-ring	ID 15,60 x 1,78
70	Back. ring	PTFE rd 16,1 x 19 x 1,4

ACCESSORIES

Proportional amplifier	Register 1.13
Mating connector black (B)	Article no. 219.2002
Flange body / sandwich plate NG4-Mini	Data sheet 2.6-820
Flange body / sandwich plate NG6	Data sheet 2.6-840
Threaded body	Data sheet 2.9-205
Technical explanations	Data sheet 1.0-100
Filtration	Data sheet 1.0-50

SURFACE TREATMENT

- ◆ The cartridge body is gas-nitro-carburised
- ◆ The armature tube and the slip-on coil are zinc- / nickel-coated

INSTALLATION NOTES

Mounting type	Screw-in cartridge M22 x 1,5
Mounting position	Any, preferably horizontal
Tightening torque	$M_D = 60 \text{ Nm}$ Screw-in cartridge $M_D = 5 \text{ Nm}$ knurled nut $M_D = 9,5 \text{ Nm}$ HB0 $M_D = 5,5 \text{ Nm}$ HB4,5

MANUAL OVERRIDE

HB4,5
 Optionally: Screw plug (HB0), no actuation possible

SEALING MATERIAL

NBR or FKM (Viton) as standard, choice in the type code

STANDARDS

Cartridge cavity	ISO 7789
Solenoids	DIN VDE 0580
Connection execution D	EN 175301 – 803
Protection class	EN 60 529
Contamination efficiency	ISO 4406