

2-way flow control valve
Screw-in cartridge
Fixed orifice, adjustable pressure compensator
M18x1,5

ISO 7789

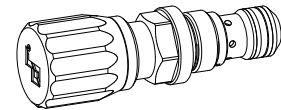

- $Q_{max} = 17$ l/min
- $Q_{Nmax} = 12,5$ l/min
- $p_{max} = 315$ bar

DESCRIPTION

2-way screw-in cartridge-type flow control valve with M18x1,5 thread, for pressure cavity acc. to ISO 7789. The valve is available in two different setting versions: Spanner setting „S“ and turning knob „D“. In its standard form, this control valve can be supplied with five nominal volume flow ranges. The two part cartridge body is made of steel. The surface of the valve is zinc-coated plated for rust protection.

FUNCTION

The 2-way flow control valve is designed to keep the speed of a consumer constant irrespective of the load. The fixed measuring orifice which is integrated into the pressure compensating piston determines the volume flow. If there is a pressure change, the pressure compensating spool is displaced and changes the outlet diameter in order to keep the pressure difference on the measuring orifice constant. By varying the spring bias acting on the compensator spool the flow rate can be changed. Minimum adjustable flow within 40...70% of $Q_{nominal}$. Flow regulation is effective above Δp 10 bar approx. Backward flow depends on load.

APPLICATION

For use in all hydraulic systems where the supply volume flow needs to be kept constant even when the load fluctuates. Installation of the screw-in cartridge in control blocks as well as in the Wandfluh sandwich plates (vertical stacked systems) and flange valves of the NG3-Mini size. (Please note the separate data sheets in register 2.5). Cavity tools are available for machining the cavities in steel and aluminium (hire or purchase). Please refer to the data sheets in register 2.13.

TYPE CODE

		QA	<input type="checkbox"/>	PM18	-	<input type="checkbox"/>	#	<input type="checkbox"/>
Flow control valve, 2-way								
Type of adjustment	Screw	<input type="checkbox"/>	S					
	Turning knob	<input type="checkbox"/>	D					
	Cover	<input type="checkbox"/>	A	(see data sheet 2.0-50)				
Screw-in cartridge M18x1,5								
Nominal volume flow rate Q_N	0,4...0,6 l/min	<input type="checkbox"/>	0,63					
	0,8...1,25 l/min	<input type="checkbox"/>	1,25					
	1,3...2,1 l/min	<input type="checkbox"/>	2					
	2,5...5,0 l/min	<input type="checkbox"/>	5					
	5,0...12,5 l/min	<input type="checkbox"/>	12,5					
Design-Index (Subject to change)								

GENERAL SPECIFICATIONS

Denomination	Flow control valve 2-way
Construction	Screw-in cartridge for cavity acc. to ISO 7789
Mounting	Screw-in thread M18x1,5
Ambient temperature	-20...50 °C
Mounting position	any
Fastening torque	$M_D = 30$ Nm
Weight:	$m = 0,09$ kg (screw) $m = 0,1$ kg (knob)
Volume flow direction:	1 → 2 adjustable flow 2 → 1 free flow

HYDRAULIC SPECIFICATIONS

Fluid	Mineral oil, other fluid on request
Contamination efficiency	ISO 4406:1999, class 18/16/13 (Required filtration grade $\beta_{6...10} \geq 75$) refer to data sheet 1.0-50/2
Viscosity range	12 mm ² /s...320 mm ² /s
Fluid temperature	-20...+70 °C
Peak pressure	$p_{max} = 315$ bar
Minimum pressure for controlled flow	$\Delta p_{min} = 10$ bar
Nominal volume flow rates:	$Q_N = 0,63$ l/min, $Q_N = 1,25$ l/min, $Q_N = 2$ l/min, $Q_N = 5$ l/min, $Q_N = 12,5$ l/min
Min. volume flow	$Q_{min} = 0,4$ l/min
Max. volume flow	$Q_{max} = 17$ l/min
Hysteresis	depending on nom. volume flow 3...8%

SYMBOLS

simplified

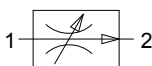

detailed

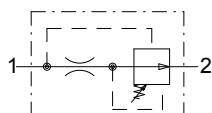
MECHANICAL ACTUATION

Mechanical types of operation in 2 different versions:

- S = Screw adjustment
with fork wrench and Allen key
- D = Control knob adjustment, fixed
Control stroke $S_b = 5$ mm
Control angle $\alpha_b = 1800^\circ / 5$ turns

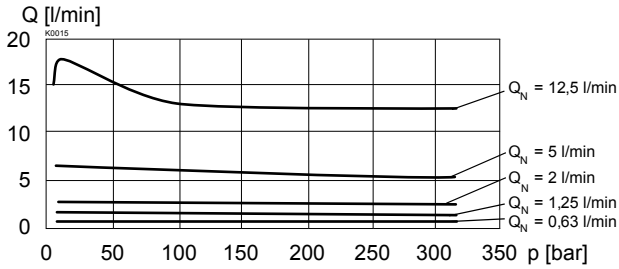
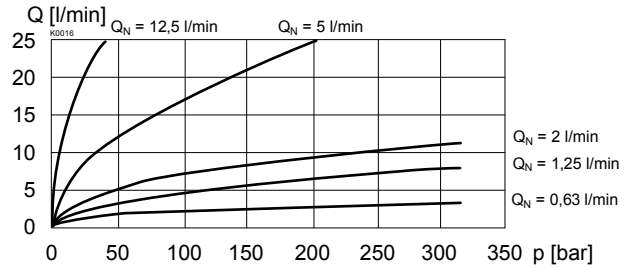
CHARACTERISTICS Oil viscosity $\nu = 30 \text{ mm}^2/\text{s}$
 $Q = f(p)$ Pressure drop-flow characteristics

 $\Delta p = f(Q)$ Pressure drop characteristics for return flow (from 2 → 1)

DIMENSIONS / SECTIONAL DRAWING

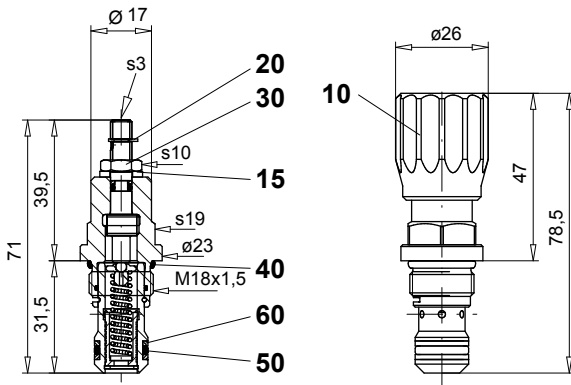
Screw adjustment „S“

Knob adjustment „D“

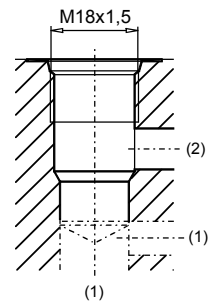

Cavity drawing according to ISO 7789-18-01-0-98



For detailed cavity drawing and cavity tools see data sheet 2.13-1002.

PARTS LIST

Position	Article	Description
10	114.2299	Knob
15	234.1060	Disc
20	193.1040	Safety plate RD4 DIN 6799
30	153.1302	Hexagonal nut 0,5D M6x3,2
40	160.2156	O-ring ID 15,60x1,78
50	160.2111	O-ring ID 11,11x1,78
60	049.3156	Back-up ring RD 12,1x15x1,4

ACCESSORIES

Sandwich plate NG3-Mini Data sheet 2.5-700

Line mount body Data sheet 2.9-205

Technical explanation see data sheet 1.0-100