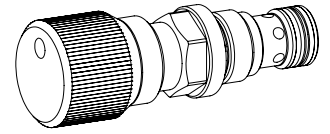

**Throttle non-return cartridge stainless**

- ◆  $Q_{max} = 25 \text{ l/min}$
- ◆  $Q_{Nmax} = 25 \text{ l/min}$
- ◆  $p_{max} = 350 \text{ bar}$

**M18 x 1,5**  
**ISO 7789**

**DESCRIPTION**

Mechanically adjustable throttle valve in screw-in cartridge construction for cavity according to ISO 7789. The one-piece throttle non-return spool shifts into the completely open position with the volume flow direction 2 to 1. The opening pressure of the valve is 1 bar. With the volume flow direction from 1 to 2, the spool is pressed against the adjustment spindle and reduces the volume flow to the required extent via the throttle area, resp., throttle notch, milled laterally on the cone. When the adjustment spindle is screwed out, the throttle closes practically leakage-free from 1 to 2, because the hydraulic pressure and the spring press the throttle non-return spool into the closed position. The stainless execution is especially suitable for the use in wet and salty environment.

**APPLICATION**

Throttle non-return valves are used where the volume flow in the one direction via the spring loaded non-return valve has to be nearly free. In the opposite direction, the oil flows via the continuously adjustable, load depending throttle. The screw-in cartridge is perfectly suitable for installation in control blocks and is installed in sandwich plates (vertical stacked systems, corresponding data sheets in this register). For machining the cartridge cavity in steel and aluminum blocks, cavity tools are available (hire or purchase). Please refer to the data sheets in register 2.13.

**SYMBOL**

**ACTUATION**

Actuation	Adjustment spindle M8 x 1
Execution	S = blockable key adjustment D = blockable knob adjustment Optionally: G = star handle adjustment → see Data sheet 2.0-50
Actuation angle	$\alpha_b = 1800^\circ$ (5 rotations)
Actuation stroke	$S_b = 5 \text{ mm}$

**TYPE CODE**

Throttle non-return valve		DR	<input type="checkbox"/>	PM18	-	<input type="checkbox"/>	-	<input type="checkbox"/>	K9	#	<input type="checkbox"/>
Type of adjustment	Key <input type="checkbox"/> S Control knob <input type="checkbox"/> D Cover <input type="checkbox"/> A										
Screw-in cartridge M18 x 1,5											
Nominal volume flow rate $Q_N$	3,2 l/min <input type="checkbox"/> 3,2 25 l/min <input type="checkbox"/> 25										
Sealing material	NBR <input type="checkbox"/> FKM (Viton) <input type="checkbox"/> D1 NBR 872 <input type="checkbox"/> Z604										
Stainless											
Design index (subject to change)											

2.4-610S

**GENERAL SPECIFICATIONS**

Designation	Throttle non-return valve
Mounting	Screw-in cartridge construction
Nominal size	M18 x 1,5 according to ISO 7789
Ambient temperature	-25...+90 °C
Weight	0,09 kg key adjustment 0,13 kg control knob adjustment 0,16 kg cover
MTTFd	150 years

**HYDRAULIC SPECIFICATIONS**

Working pressure	$p_{max} = 350 \text{ bar}$
Maximum volume flow	$Q_{max} = 25 \text{ l/min}$
Volume flow direction	1 → 2 adjustable flow 2 → 1 free flow
Nominal volume flow	$Q_N = 3,2; 25 \text{ l/min}$ at 10 bar valve pressure drop
Leakage oil	With closed throttle practically leakage-free
Fluid	Mineral oil, other fluid on request
Viscosity range	12 mm <sup>2</sup> /s...320 mm <sup>2</sup> /s
Temperature range fluid	NBR -25...+90 °C FKM (D1) -20...+90 °C NBR 872 (Z604) -40...+90 °C
Contamination efficiency	Classe 20 / 18 / 14...21 / 19 / 15
Filtration	Required filtration grade $\beta_{10...25} \geq 75$ , see data sheet 1.0-50 / 2

**SEALING MATERIAL**

NBR or FKM (Viton) as standard, choice in the type code

**PERFORMANCE SPECIFICATIONS**

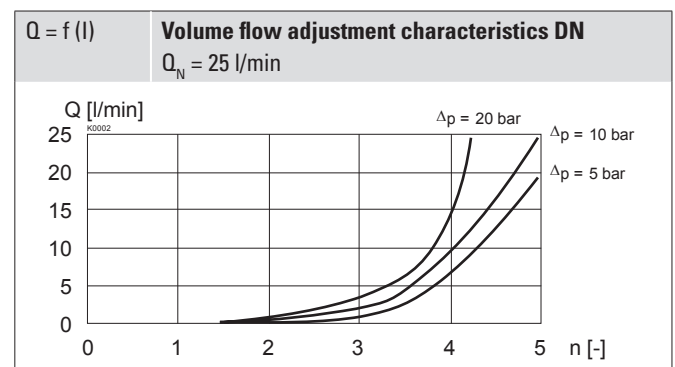
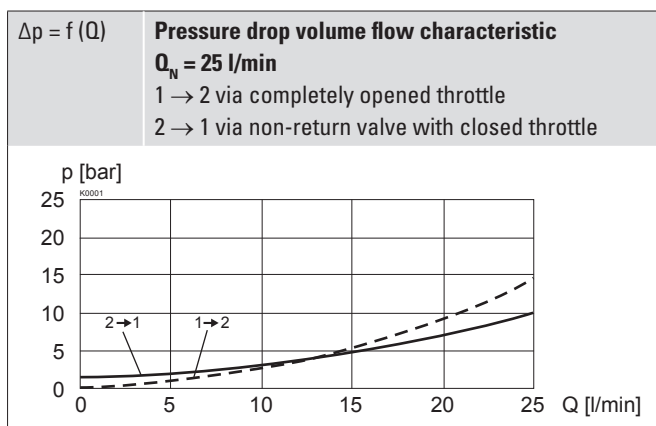
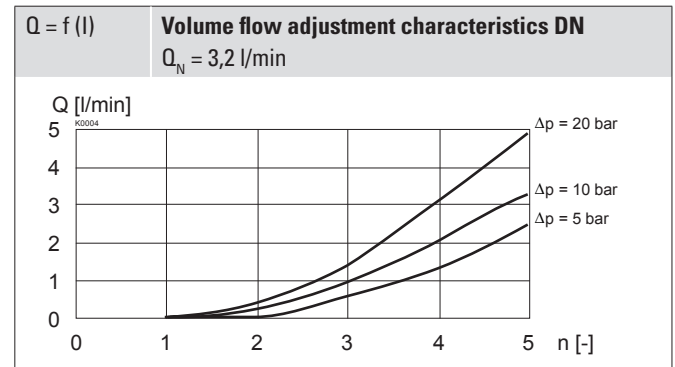
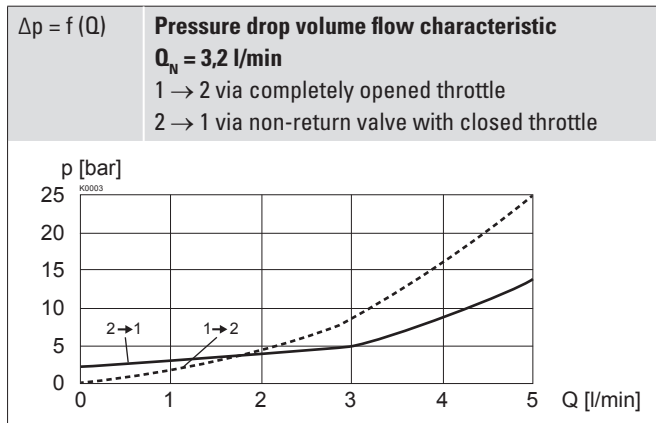
 Oil viscosity  $\nu = 30 \text{ mm}^2/\text{s}$ 

**DIMENSIONS**

Key adjustment „S”

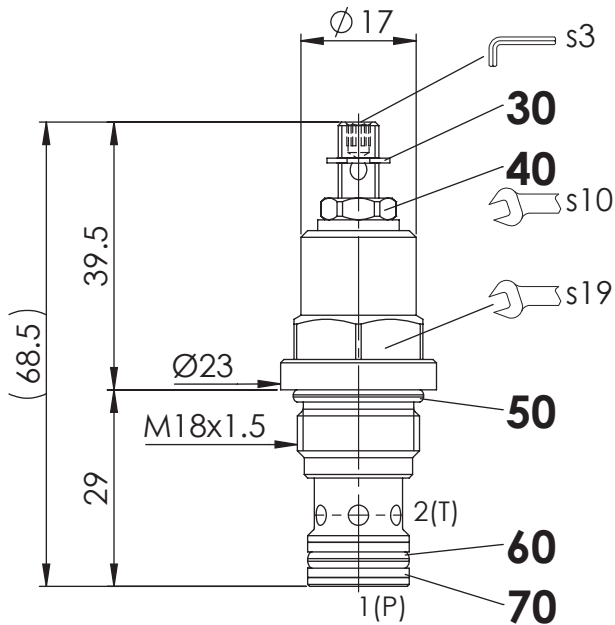

Control knob adjustment „D”

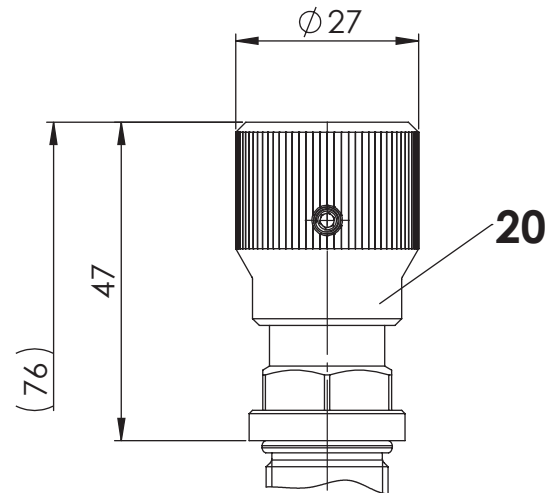

Cover „A”

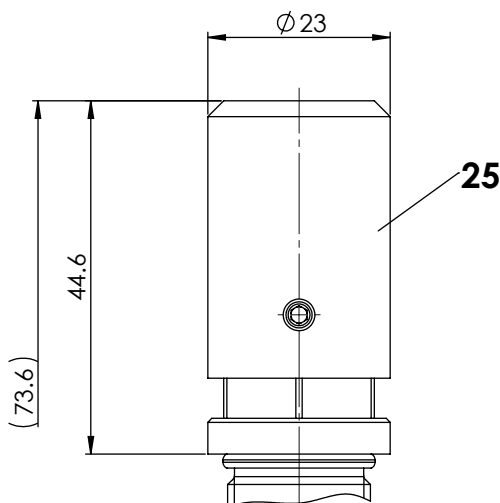

Star handle „G”

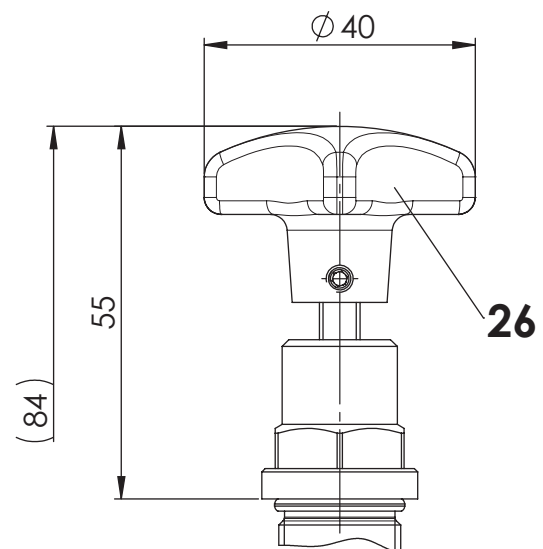
**HYDRAULIC CONNECTION**

Cavity drawing according to ISO 7789-18-01-0-98

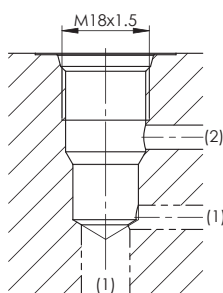

Note! For detailed cavity drawing and cavity tools see data sheet 2.13-1002

**PARTS LIST**

Position	Article	Description
20	114.2228	Control knob K9
25	032.0616	Cover rd 23 / 3 x 35 K9
26	082.2004	Star handle rd 40 x 26
30	193.1042	Retainer stainless rd 4 DIN 6799
40	153.1303	Hexagon nut 0,5d A4 M6 x 3,2
45	234.1060	Washer DIN 125A M6
50	160.2156	O-ring ID 15,60 x 1,78 (NBR)
	160.6156	O-ring ID 15,60 x 1,78 (FKM)
60	160.2111	O-ring ID 11,11 x 1,78 (NBR)
	160.6111	O-ring ID 11,11 x 1,78 (FKM)
70	049.3156	Backup ring rd 12,1 x 15 x 1,4

## ACCESSORIES

Types of adjustment for screw-in cartridges	Data sheet 2.0-50
Technical explanations	Data sheet 1.0-100
Filtration	Data sheet 1.0-50

## INSTALLATION NOTES

Mounting type	Screw-in cartridge M18 x 1,5
Mounting position	Any, preferably horizontal
Tightening torque	$M_D = 40$ Nm Screw-in cartridge

## SURFACE TREATMENT

- ◆ The cartridge body and the control knob are made of stainless steel

## STANDARDS

Cartridge cavity	ISO 7789
Contamination efficiency	ISO 4406